

PPE-0318P-E(B)16-Port 100 Mbps Long-Range Unmanaged PoE Switch

PPE-0318P-E is a layer 2 100 Mbps PoE switch. Based on wire-speed forwarding, the switch supports Ethernet PoE power supply and extend mode. The power supply distance reaches as long as 250 m. It also supports prior and stable transmission of the important surveillance area video when connected to the high priority ports.



Feature and Function

- 16 × 100 Mbps PoE ports, and 2 × 1000 Mbps combos.
- IEEE 802.3at/af standard.
- IEEE 802.3, IEEE 802.3u and IEEE 802.3x standard.
- High priority ports.
- 8-core power supply.
- Upstream port link aggregation.
- Up to 250 m transmission distance.
- 6 KV surge protection PoE ports.
- PoE power management.
- 100 Mbps network access.
- Wire-speed forwarding and non-blocking design.
- Store-and-forward switching.
- Solid high-strength metal shell.

Specification

Model		PPE-0318P-E(B)
Network parameters	Port number	16 × 100 Mbps PoE ports, 2 × 1000 Mbps combos
	Port type	RJ45 port, full duplex, MDI/MDI-X adaptive
	Standard	IEEE 802.3, IEEE 802.3u, IEEE 802.3x
	Forwarding mode	Store-and-forward switching
	Working mode	Standard mode (default); Extend mode
	High priority ports	Ports 1 to 8
	Ports for long-distance transmission	Ports 9 to 16
	Link aggregation port	G1 to G2
	MAC address table	4 K
	Switching capacity	7.2 Gbps
	Packet forwarding rate	5.356 Mpps
	Internal cache	2.75 Mbits
	PoE power supply	PoE standard
PoE power pin		Ports for long-distance transmission (9-16) support 8-core power supply, Ethernet cable 1/2/3/6 and 4/5/7/8 provide simultaneous power supply Ports for close-range transmission (1-8) support 4-core power supply, Ethernet cable 1/2/3/6 provide power supply
PoE port		Ports 1 to 16
Max. port power		30 W
PoE power budget		230 W
Max. power consumption		250 W
General	Shell	Metal material
	Gross weight	3.47 kg (7.65 lb)
	Net weight	2.65 kg (5.84 lb)
	Dimension (L × H × D)	440 mm × 44 mm × 220.8 mm (17.3" × 1.73" × 8.7")
	Operating temperature	-10 °C to 55 °C (14 °F to 131 °F)
	Storage temperature	-40 °C to 85 °C (-40 °F to 185 °F)
	Operating humidity	5% to 95% (no condensation)
	Storage humidity	5% to 95% (no condensation)
	Power supply	100 to 240 VAC, 50/60 Hz, Max. 4 A
	Power consumption in idle	20 W

Physical Interface

Front panel:

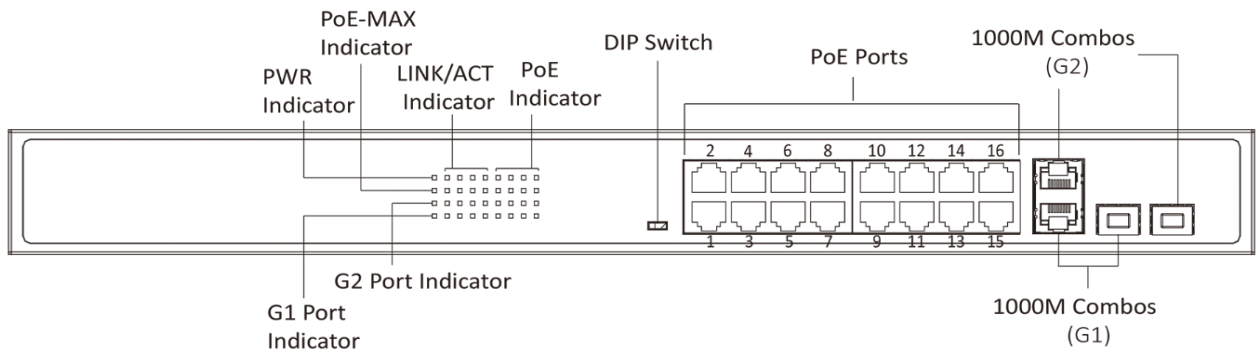

Back panel:



Available Model

PPE-0318P-E



NOTE

Dimension (unit: mm)

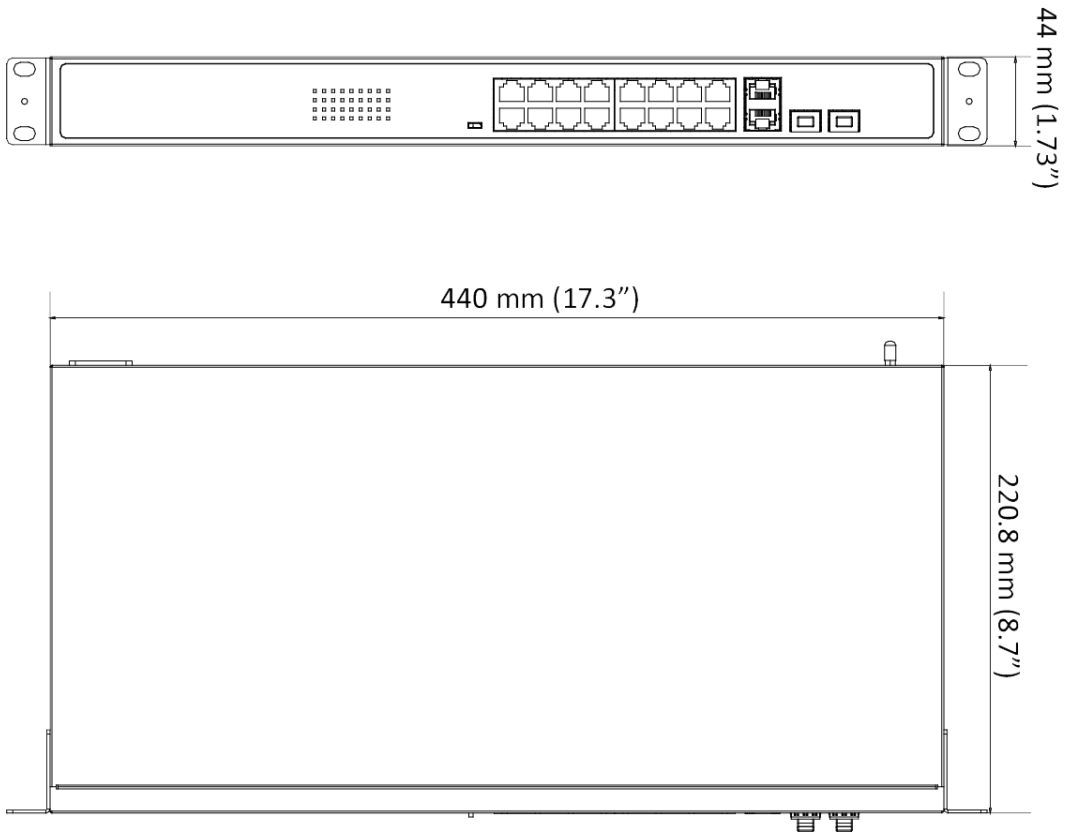

Typical Application

